

Vaccine: Mammalian Cell

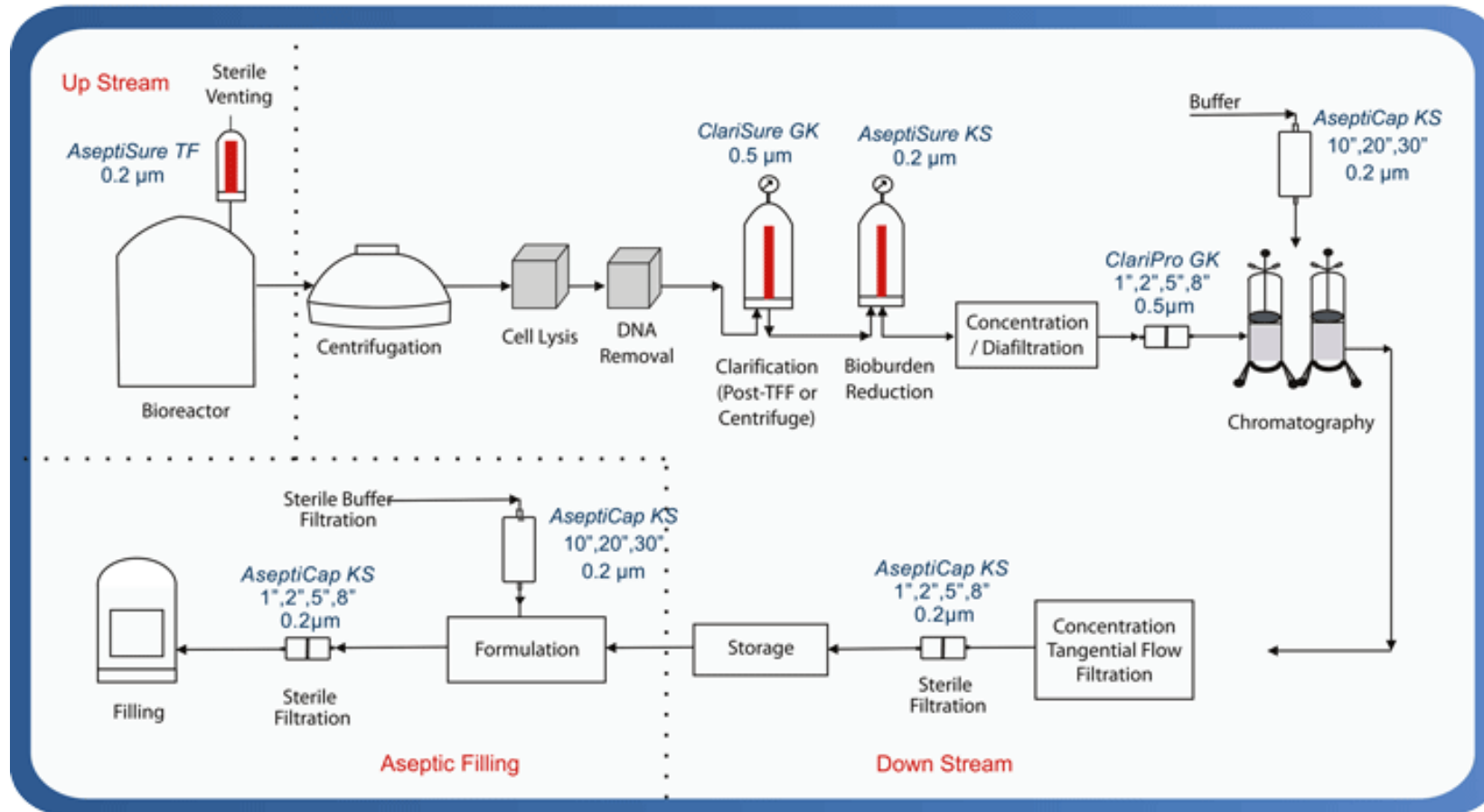

Vaccine: Viral Vectors

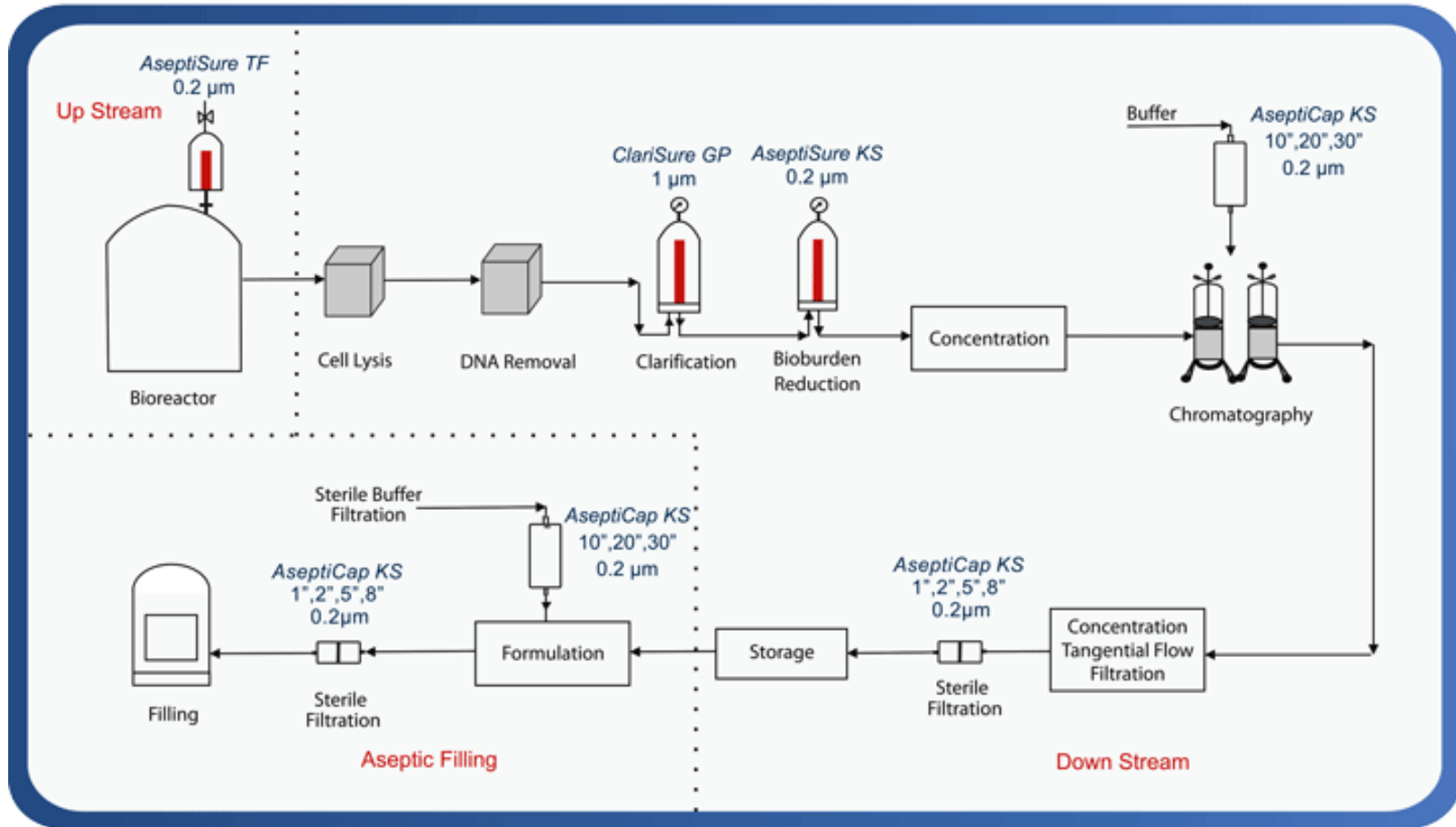

Vaccine: Plasmid DNA

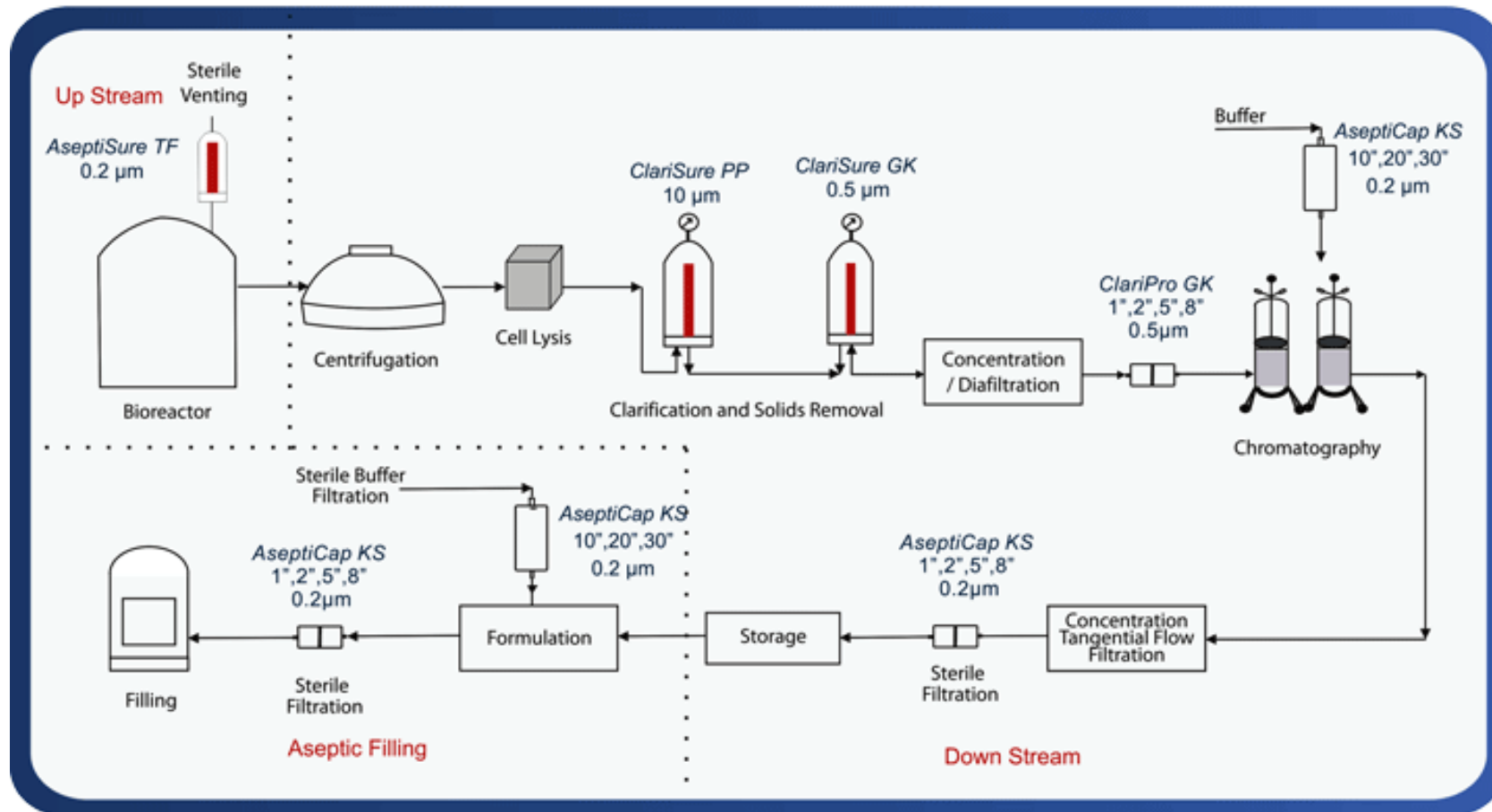

Vaccine: Conjugates

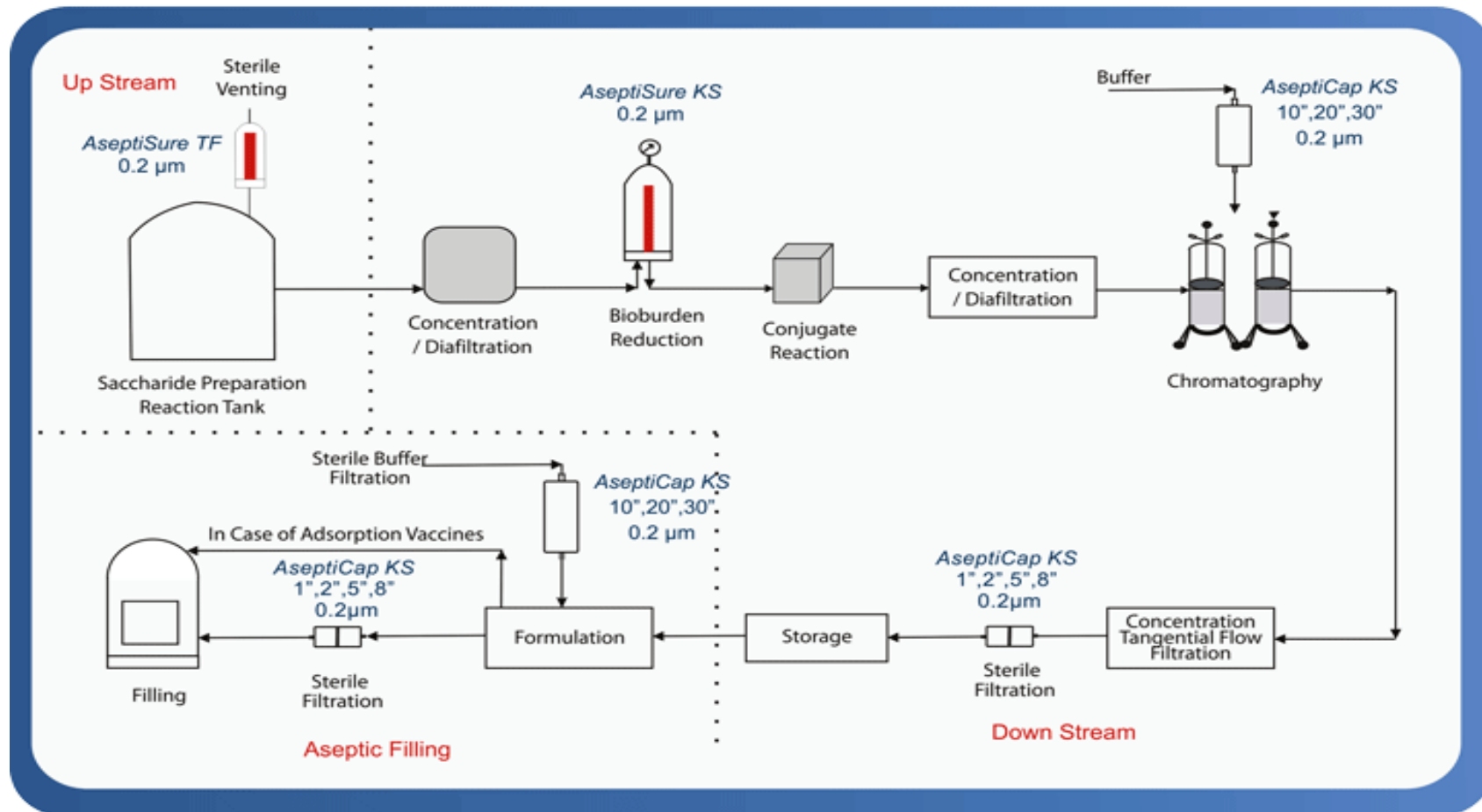

Vaccine: Polysaccharides

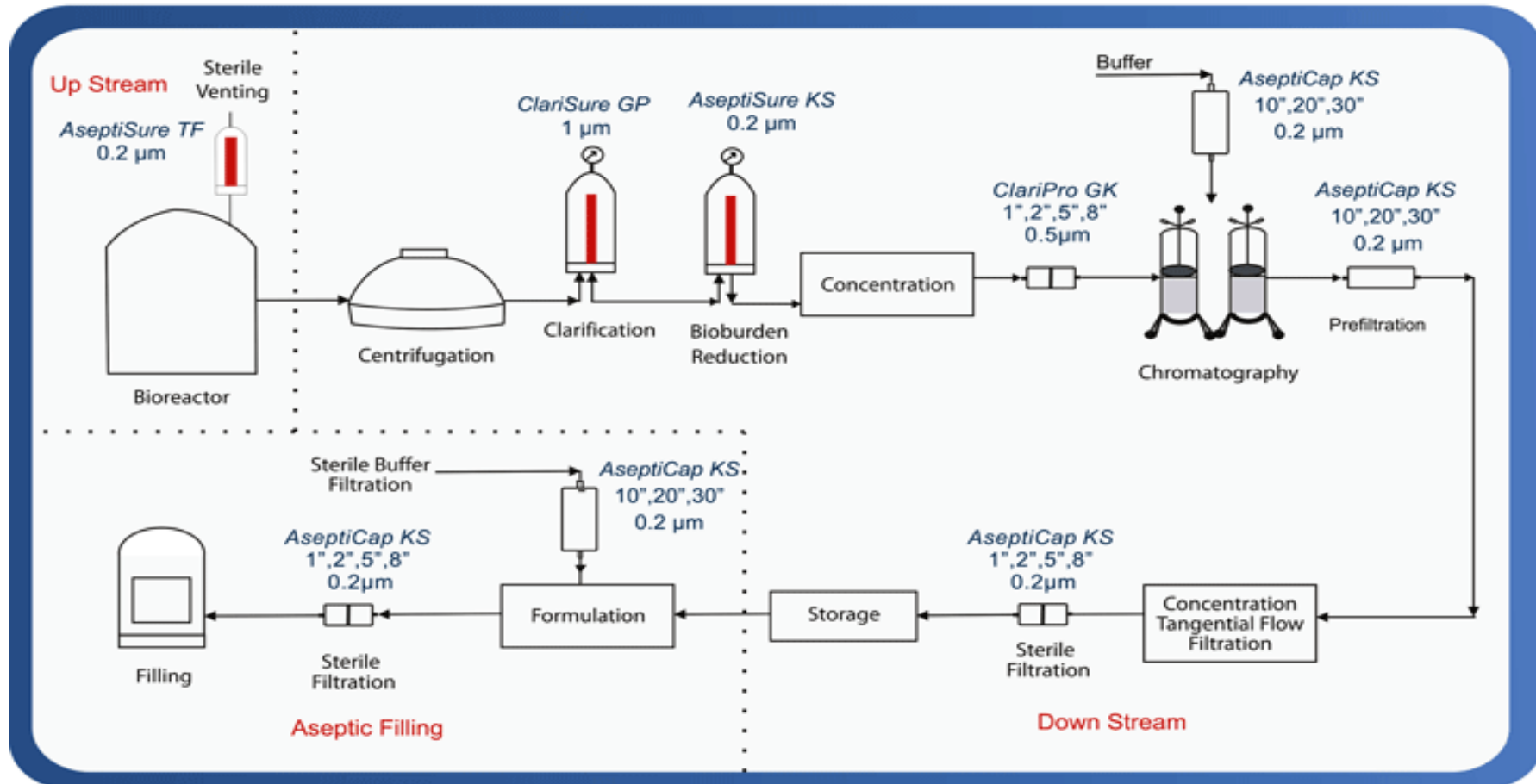

Microbial Fermentation

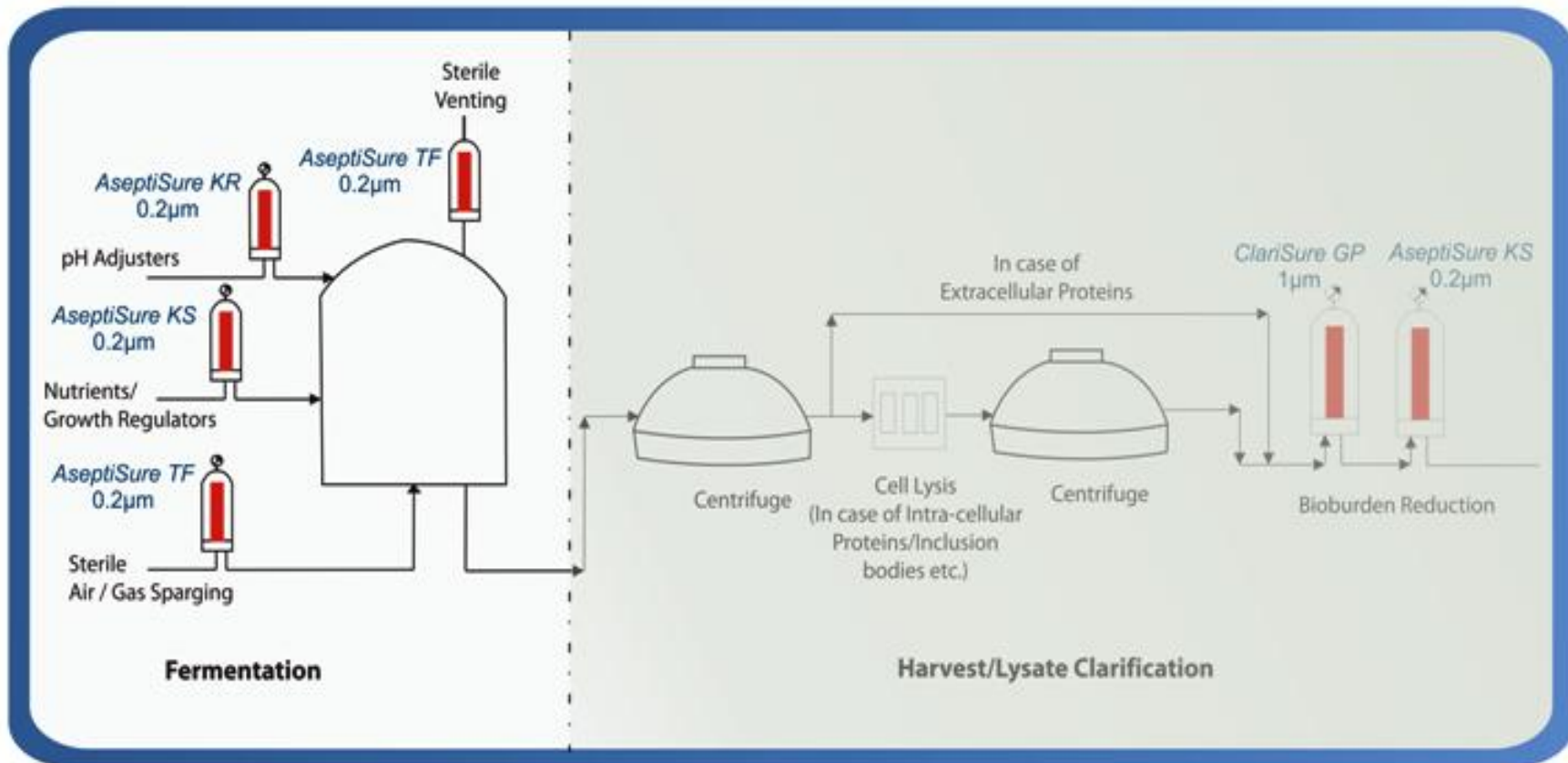

Microbial Fermentation Broth Clarification

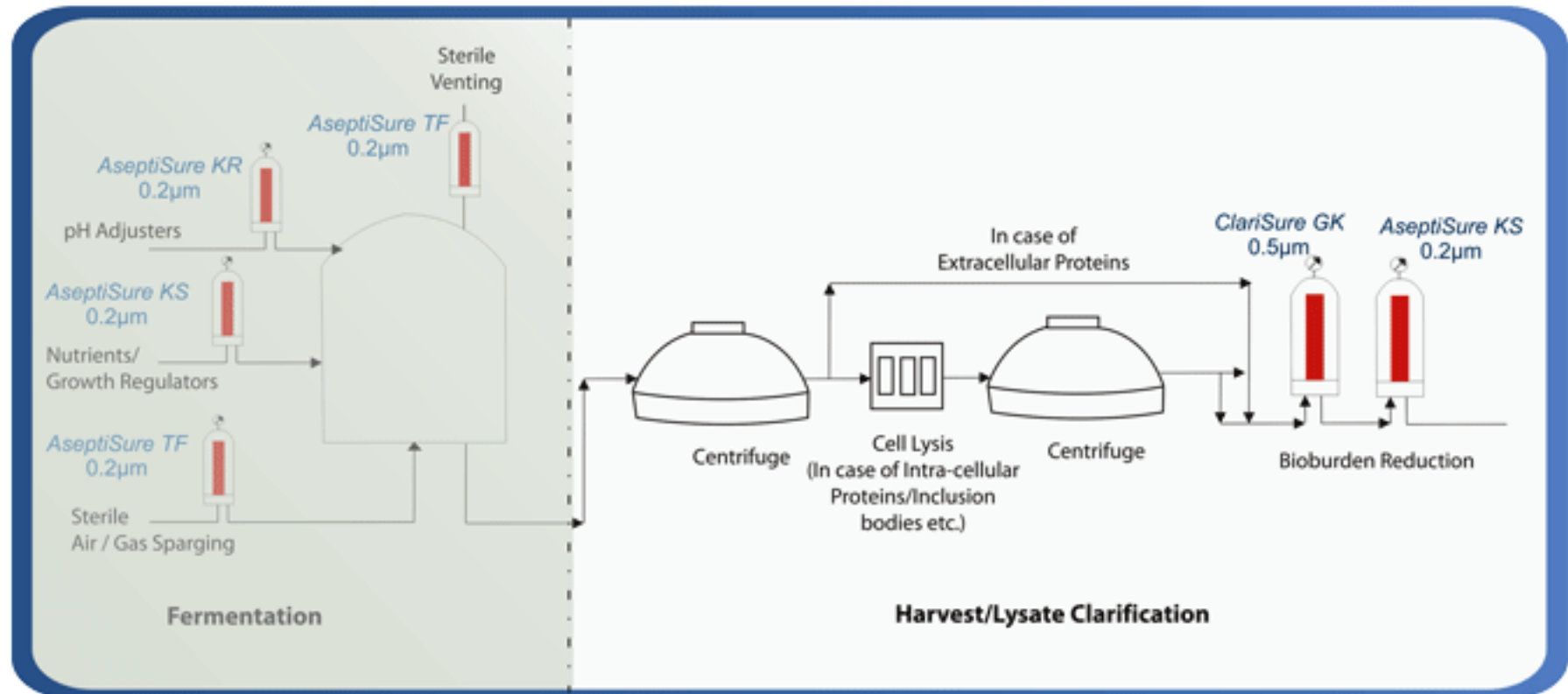

Downstream Processing

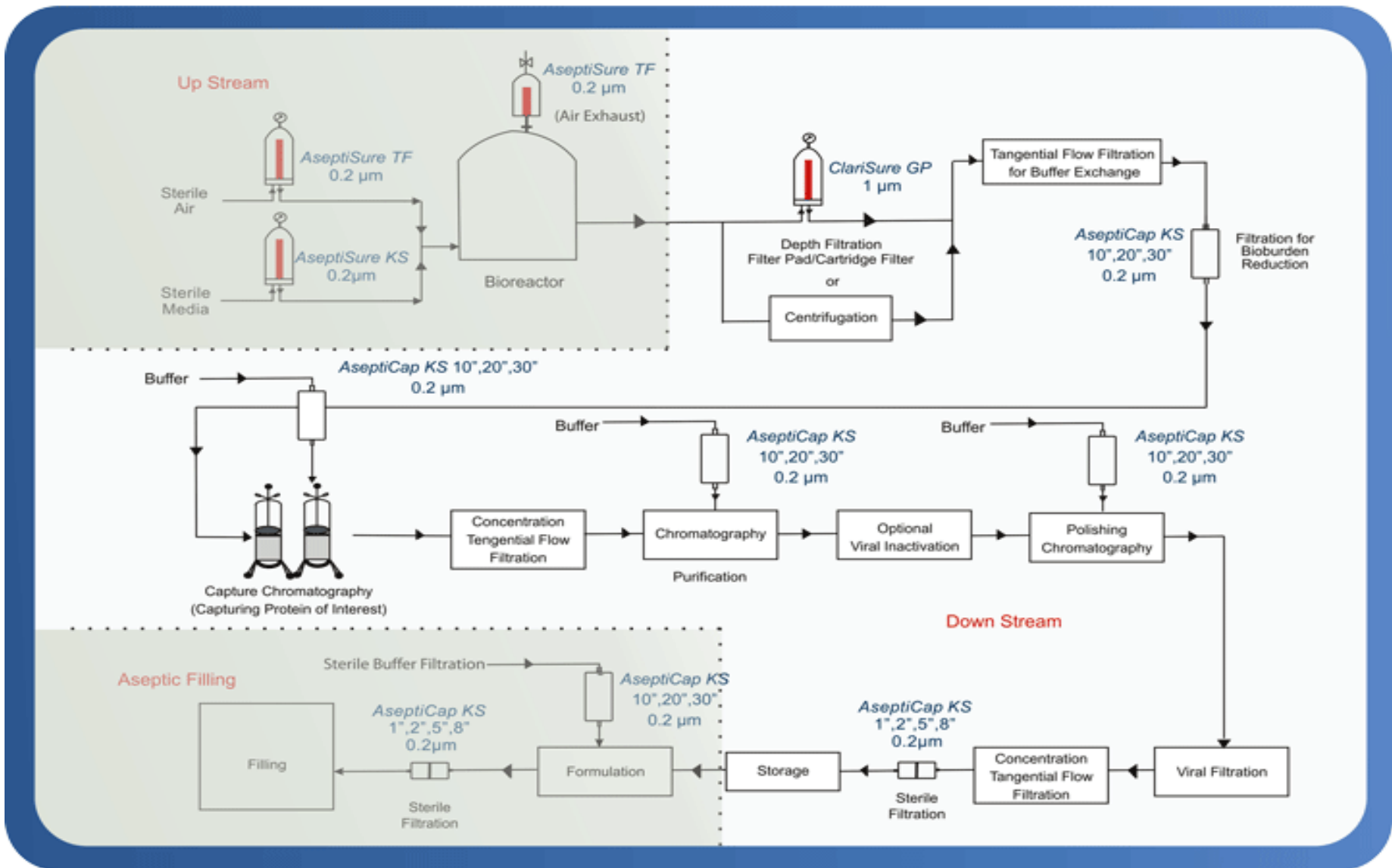

Aseptic Fill and Finish

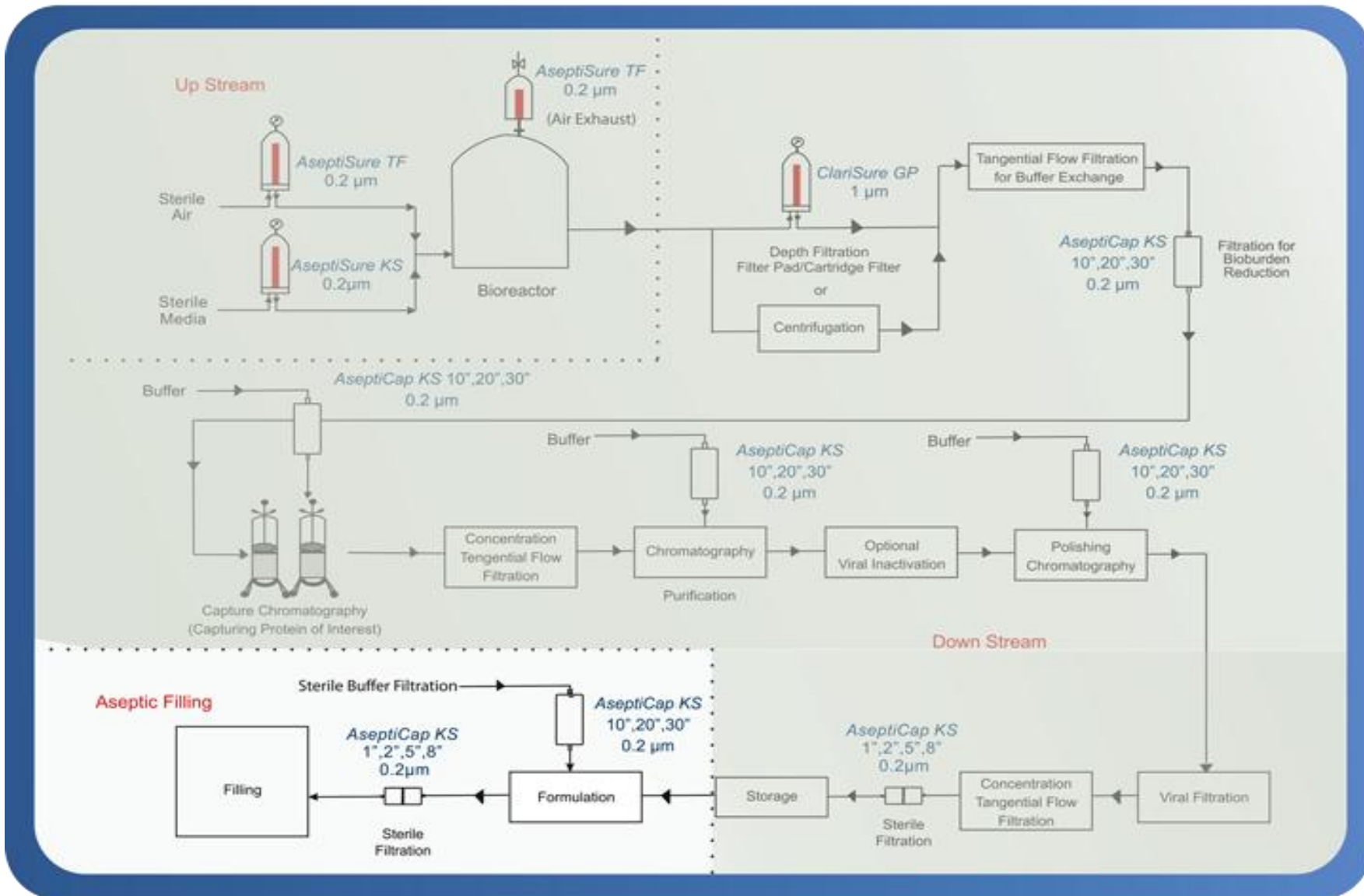

Plasma Fractionation: Albumin

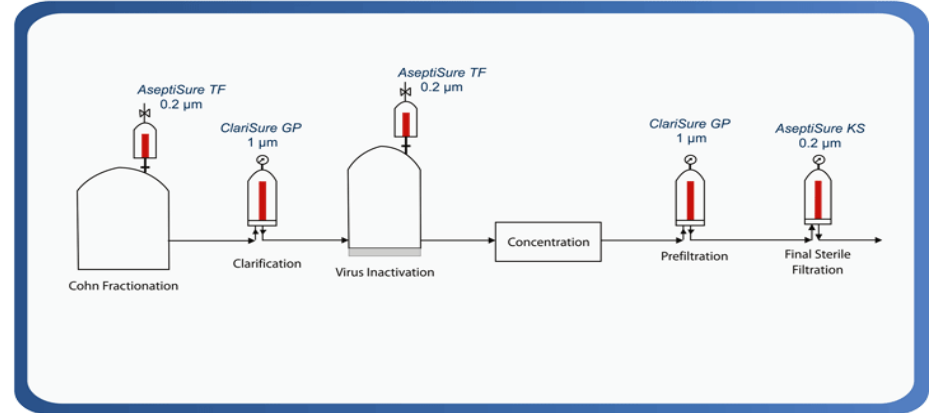

Plasma Fractionation: Clotting Factors

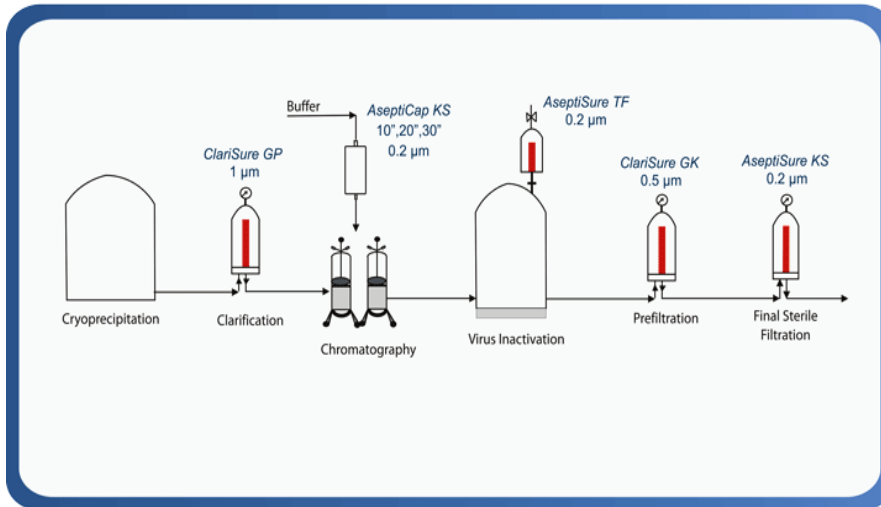

mdi
Membrane Technologies

Kemiteks
Kimyevi Mad.Tic.Ltd.Şti